

## NAVIGAT 100



NAVIGAT 100 is the advancement of the Northrop Grumman Sperry Marine spinning mass gyrocompasses.

The NAVIGAT 100 fully integrates the benefits of the NAVIGAT family of products within a single unit.

### Features

---

- CompassNet single unit
- 180° heading offset function for shuttle vessels
- Built-in test equipment
- Automatic North Speed Error Correction
- HSC Approved
- Low lifecycle costs
- Short installation time
- High-speed follow-up system 100°/sec
- High resolution ROT output

The NAVIGAT 100 is type approved by DNV GL in compliance with:

- 96/98/EC Marine Equipment Directive 2015/559 April 2015 (wheelmark)
- IMO A.424(XI), A.694(17) A.526(13) (Rate of Turn), MSC.191(79), A.821(19)-(HSC), MSC.36(63)-(1994 HSC Code), MSC.97(73)-(2000 HSC Code), ISO 16328(2014). Compliant with the requirements of DNV GL Rules for Ships Pt.6 Ch.3 (INS)
- IEC 61162, IEC 62288 Ed 2.0 (2014-07).

# Performance, Specifications and I/O Signals

## Performance

Linear mean settle point error (RMS)	≤ 0.1° Secant latitude
Static error (RMS)	≤ 0.1° Secant latitude
Dynamic error	≤ 0.4° Secant latitude
Heading Resolution	0.1
Rate of Turn Resolution	≤ 0.5 ± 5% °/min
Freedom of Roll & Pitch	± 40°
Settling Time	2.9h
Follow-Up rate	100°/sec
MTBF	120,000
North stabilization at power interruption	~3min

## Operations

Power Supply	DC 24V AC 115/230V (external ps)
Power Consumption	Start-Up 96W Operations 64W Analogue Repeater +7W per Repeater Universal Digital Repeater +5W per Repeater
Temperature range	Operation -10°C to +55°C Storage -25°C to +70°C
Power Failure Alarm	Visible, audible and potential no contact
Protection Grade	IP 23 as per IEC/EN 60529
Environmental Req & EMC Magnetic Clearance to:	<i>In accordance with</i> EN60945 (IEC 945 +1) Standard Magnetic Compass 0.5m Steering Magnetic Compass 0.35m
Reduced Magnetic Clearance to:	Standard Magnetic Compass 0.3m Steering Magnetic Compass 0.3m

## I/O signals

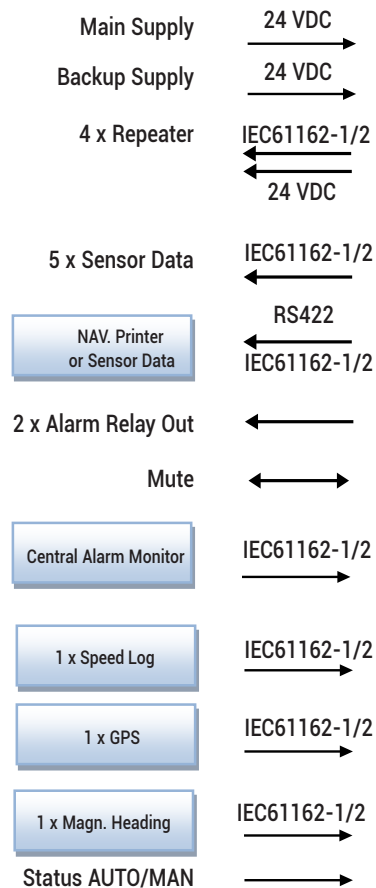

## Accessories



Bearing repeater compass with 360° card in a stand with azimuth device



Bearing Repeater Compass with 360° card in bulwark console



Prismatic Azimuth Device PV 23



Repeater compass steering, console, bulk-head

For more information, please contact:

### AMERICAS

New Orleans, LA USA  
Tel: +1-504-328-9171

### ASIA

China, Shanghai  
Tel: +86-21-5179-0199  
Hong Kong, Sheung Wan  
Tel: +852-2581-9122  
Japan, Tokyo  
Tel: +81 (03)-3863-7401  
Singapore  
Tel: +65-6274-3332  
South Korea, Busan  
Tel: +82-51-247-7455

### CANADA

Nova Scotia, Halifax  
Tel: +1-902-468-9479  
British Columbia, Vancouver  
Tel: +1-604-821-2090

### EUROPE

Belgium, Antwerp  
Tel: +32 (0)3233-1433  
Denmark, Copenhagen  
Tel: +45 (0)77-33-6633  
Germany, Hamburg  
Tel: +49 (0)40-299-000  
The Netherlands, Vlaardingen  
Tel: +31 (0)10-445-1600  
Norway, Bergen  
Tel: +47 (0)55-94-9494  
United Kingdom, London  
Tel: +44 (0)20-8329-2000

[www.sperrymarine.com](http://www.sperrymarine.com)

Specifications and features subject to change without notice.  
©2017 Northrop Grumman Systems Corporation  
All rights reserved.

BR-01/EXP-KK  
OPC\_04/17

